

April 7, 2023

Version 1

2024 Integra: TQI Information

AFFECTED VEHICLES

Year	Model	Trim Level
2024	Integra	Standard
		A-Spec
		A-Spec with Tech
		A-Spec with Tech 6MT

INTRODUCTION

This bulletin covers the Total Quality Inspection (TQI) of the 2024 Integra. It includes these procedures:

1. Remove the Exterior Protective Coatings
2. Install the Fuses
3. Cancel Maintenance Mode
4. Set the Tire Pressures and Verify the Pressures Displayed
5. Remove the Interior Protective Coverings
6. Install the Floor Mats
7. Check the Battery
8. Install the Body Plugs
9. Install the Front Licenses Plate Holder and Rear License Plate Hardware
10. Fuel the Vehicle
11. Remove the Exterior Protective Coatings
12. Do the PCM Idle Learn Procedure
13. Do the CKP-Pattern Learn Procedure
14. Install the Shift Lock Release Cover
15. Activate the Audio System, and Set the AM/FM Audio Unit Presets
16. Set the Clock
17. Voice Control System
18. Rearview Camera
19. Check/Refresh the SiriusXM Radio Dealer Demo Service (Except Alaska and Hawaii, if equipped)
20. Placing Windshield Wipers into Maintenance Mode
21. Event Data Recorders

This vehicle is no longer equipped with an embedded navigation system. Navigation maps can be viewed using a smartphone connected through Apple Carplay and Android Auto.

CLIENT INFORMATION: The information in this bulletin is intended for use only by skilled technicians who have the proper tools, equipment, and training to correctly and safely maintain your vehicle. These procedures should not be attempted by “do-it-yourselfers,” and you should not assume this bulletin applies to your vehicle, or that your vehicle has the condition described. To determine whether this information applies, contact an authorized Acura automobile dealer.

CLAIM INFORMATION

Reimbursement Time: 1.4 hours

TQI PROCEDURES

Before Starting

Review these items:

- Perfect Delivery documents, especially the information on battery maintenance and tire pressures
- TQI checklist in the maintenance journal

Make sure you record the TQI on the appropriate pages of the checklist. The TQI is not done until this bulletin and the checklist are complete. Note on the repair order any repairs or problems that cannot be fixed within a few minutes.

Remove all TQI items from the cargo area, glove box, and cup holders.

Starting the Engine Without the Backup Fuse

To lower parasitic draw, the vehicle comes from the factory with the No. 37 BACK UP 2 (30A), and No. 19 BACK UP (15A) fuse removed from the under-hood fuse/relay box. With it removed, the engine will not start when you apply the brake pedal (press the clutch pedal on M/T models) and press the ENGINE START/STOP button.

To start the engine with the No. 37 BACK UP 2 (30A), No. 19 BACK UP (15A), fuse removed, do the following:

1. Make sure the transmission is in Park (Transmission in Neutral on M/T models) and the electric parking brake is set (the engine will not start unless it is). Press the ENGINE START/STOP button once. The indicator will blink.



2. Touch the keyless remote to the ENGINE START/STOP button.



The indicator will switch from blinking to steady when communication is complete.



3. Start the engine by pressing the ENGINE START/STOP button while applying the brake pedal (press the clutch pedal on M/T Models). You must start the engine within **10 seconds** of touching the remote to the button.

1. Remove the Exterior Protective Coatings

Carefully remove all of the exterior protective coatings, see S/B 96-009, *Removal of Protective Coatings During TQI*. Remove the factory bar code (RFID) from the windshield.

2. Install the Fuses

To lower battery drain during vehicle shipping, the No. 37 BACK UP 2 (30A), No. 36 AUDIO (30A), No. 19 BACK UP (15A), and No. 20 AUDIO (15A) (9" TOUCHSCREEN ONLY) fuses are removed from the under-hood fuse/relay box and stored in the glove box or cup holder. Make sure you set the ignition to OFF and wait at least 1 minute before installing the fuses.

NOTE: Applies to TECH trim with HUD.

If the vehicle is started without No. 19 BACK UP (15A) fuse installed, the system could trigger a DTC U1281-00 (HUD Lost Communication with BCM).

The code is stored in the background and the MIL will not come on.

This code can be cleared with the i-HDS.

To clear the stored DTC, follow these steps:

1. Connect the i-HDS to the 16 pin DLC.
2. From the **Vehicle Selection Menu**, select **DTC**.
3. From the **Vehicle Selection DTCs Menu**, select **Check All DTC's**.
4. From the **All DTC Check Menu**, select **All DTC Clear**.
5. Disconnect the i-HDS.

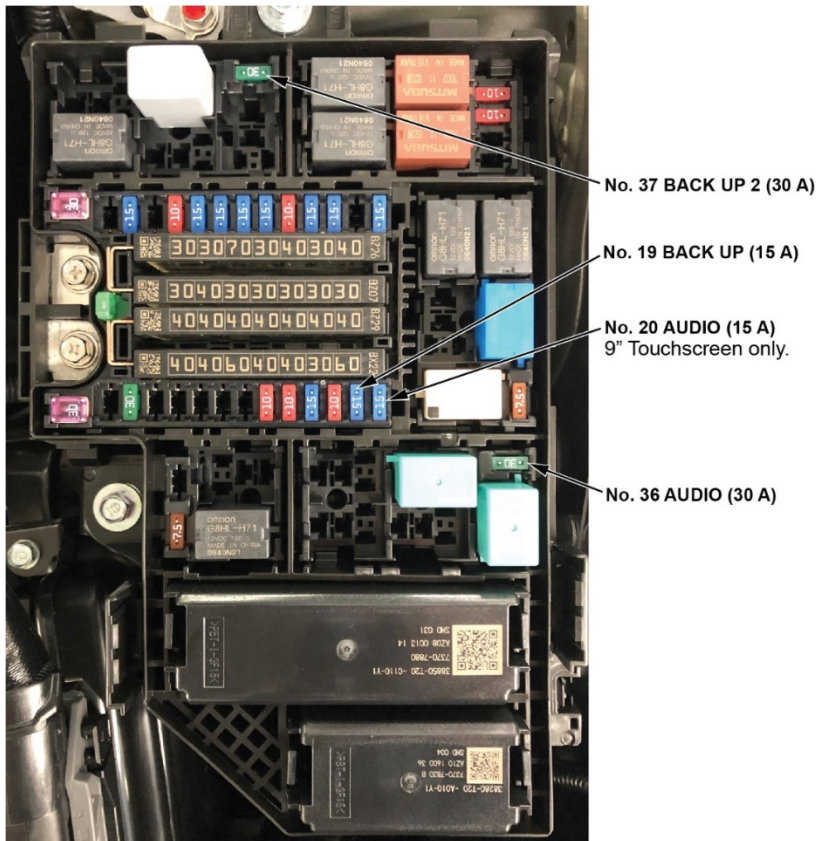

3. Cancel Maintenance Mode

Before leaving the factory, the vehicle is put into maintenance mode. Since the backup fuse is removed for shipping, this keeps the MIL from coming on from a communication loss between the PCM and the gauge control module. In this mode, the Charging System and Low Oil Pressure indicators will alternately blink. To complete the TQI, you will need to cancel maintenance mode.



To do that, make sure you have first done these actions:

1. Installed the No. 19 BACK UP (15A) and No. 37 (30A) fuses (see Install the Fuses).
2. Shift the transmission to Park or Neutral (M/T models).
3. Apply the electronic parking brake.

Then, within **20 seconds**, complete these steps:

1. Set the ignition to ON.
2. Press the brake pedal down and hold it, press and release the accelerator pedal five times, then release the brake pedal.
3. Set the ignition to OFF and wait **5 seconds**.
4. Set the ignition to ON.

NOTE: Make sure that there is no maintenance message illuminated in the MID. If it is, repeat this process.

4. Set the Tire Pressures and Verify the Pressures Displayed

To prevent flat spots during vehicle shipping and storage, the tires are inflated to over **40 psi**. If the vehicle goes into dealer storage, leave the tire pressure at **40 psi** until it is sold. When the vehicle is moved to the sales lot or is sold, adjust the tire pressures as follows:

1. Set the ignition to ON.
2. Set the pressure in each tire to the recommended value listed on the driver's doorjamb label and check it with a hand-held gauge.
3. Check to ensure that the pressures set are reflected on the vehicle display. If no value is seen, or dashes are displayed on the MID, cycle the ignition up to 9 times or until values are displayed.



4. Remove the TPMS label from each wheel. These labels are used by the factory to initialize the TPMS.

Vehicle Interior

5. Remove the Interior Protective Covering

There are several protective coverings on the interior trim pieces. Carefully remove all interior protective coverings with clean hands to avoid soiling surfaces.

Remove the steering wheel protective covering by pulling the top towards you. Do not try removing it by pulling the top away and down from you, or you will damage the cable reel. Do not use cutting tools to remove the covering; you could damage the leather.



PROPER REMOVAL



NO GOOD



Note: If any of the interior is dirty, clean it with mild soap or Acura cleaning product such as the Acura Genuine Interior Car Care Kit (P/N 08700-9311B), Leather & Vinyl Cleaner (P/N 08700-9214), or Carpet Spot Remover (P/N 08700-9215).

6. Install the Floor Mats

Install the floor mats where they belong. Be sure to place the driver's floor mat eyelets over the anchors in the floor and turn the knobs **clockwise** to lock position.

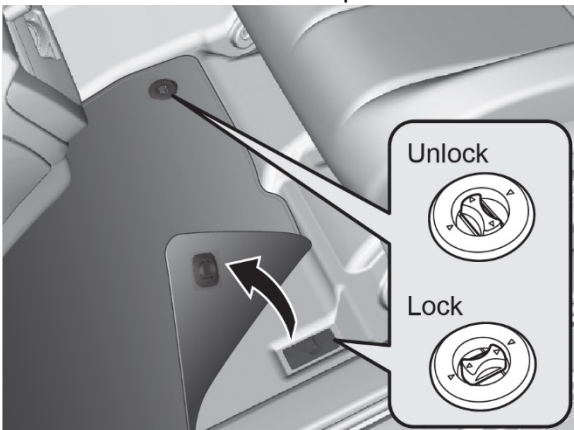

Under-Hood (Engine Idling)

7. Check the Battery

To ensure long battery life and that the client gets a fully charged battery, you must check it at these times:

- When the vehicle first arrives at the dealership
- During the TQI (if done at a later date)
- At regular intervals (if stored)
- Just before vehicle delivery

Test the battery with the ED-18 battery tester using S/B 88-016, *Battery Testing and Replacement*. Make sure the ED-18 has the latest software installed before using it. See S/B 09-027, *ED-18 Battery Tester Update Information*.

Write down the **GOOD BATTERY** 10-digit code in the Under Hood - Engine Cold section of the TQI and Final Delivery Checklist. Test the battery again at vehicle delivery and charge it if needed. Write down the new code in the Final Inspection (At Delivery) section.

NOTE: Always check the battery cables and terminal tightness when testing the battery.

If the ED-18 does not show **GOOD BATTERY** or shows **GR8 DIAGNOSTIC NEEDED**, you must charge the battery with the GR8 battery diagnostic station. Make sure the GR8 has the latest software installed before using it. See S/B 09-034, *GR8 Battery Diagnostic Station Update Information*.

Vehicle Exterior (Vehicle Raised to Full Height)

NOTE: A flat lift may interfere with under-vehicle components and the side spoiler. Use attachments that help prevent damage.

8. Install the Body Plugs

Install the body plugs as shown.

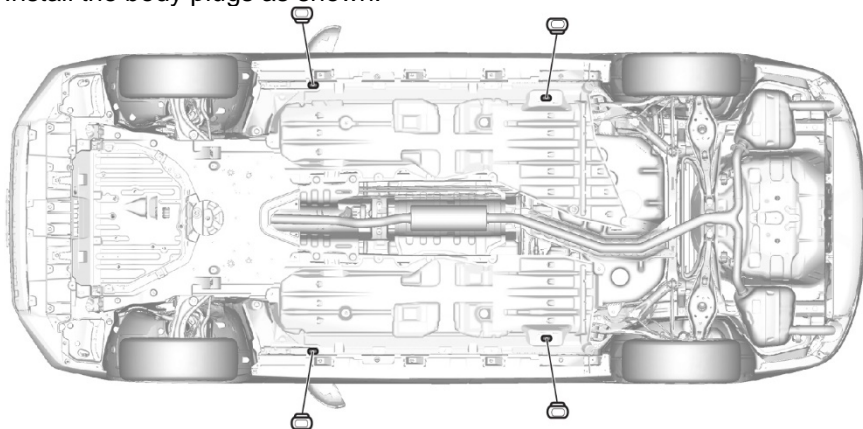

Vehicle Exterior (Vehicle Lowered to Half Height)

9. Install the Front License Plate Holder and Rear License Plate Hardware

If state regulations require the use of a front license plate, install the front license plate holder as shown.

The remaining screws are used to attach the license plate.



If state regulations require the use of a front license plate, install the front license plate holder as shown using the longer rounded Phillips's head screws. Four hex-head screws are used to attach the front plate to the holder.

Vehicle Exterior (Vehicle Lowered to Ground)

10. Fuel the Vehicle

Make sure the No. 19 BACK UP (15 A), No. 37 BACK UP 2 (30 A), No. 36 AUDIO (30 A), and No. 20 AUDIO (15 A) (9" TOUCHSCREEN ONLY) fuses are installed before filling up the fuel tank (see Install the fuses). Make sure you set the ignition to OFF and wait at least 1 minute before installing the fuses. If you, do it without them installed, the fuel gauge will take much longer than normal to show an accurate reading.

If this happens, and you do not want to wait for the gauge to show the correct level, set the ignition to OFF, and let the vehicle sit for 10 minutes. Install the fuse, then set the ignition to ON. The fuel gauge will show the correct level.

11. Remove the Exterior Protective Coatings

Carefully remove all of the exterior protective coatings. See S/B 96-009, *Removal of Protective Coatings During TQI*.

Remove the windshield Barcode Label (if equipped). Peel off the barcode label from the upper left corner of the windshield; it is for factory use only.

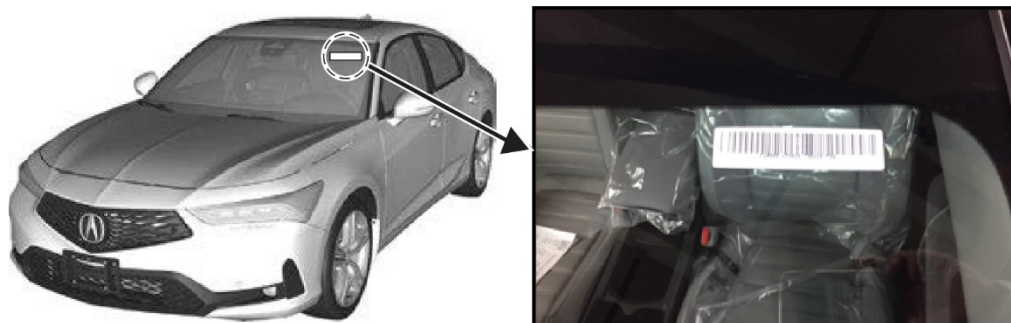

Vehicle Interior

12. Do the PCM Idle Learn Procedure

To ensure a steady engine idle, do the PCM idle learn procedure. Ensure that the No 20 BACKUP (7.5A) fuse has been installed.

NOTE: The PCM idle learn procedure must be done after updating or replacing the PCM. It does not need to be done after clearing DTCs.

1. Start the engine with the transmission in Park (Neutral on M/T models).
2. Wait for the engine to reach operating temperature (the cooling fans cycle twice).
3. Let the engine idle for **10 minutes** with the throttle fully closed.
4. Set the ignition to OFF.

13. Do the CKP-Pattern Learn Procedure

Warm up the engine by raising the engine speed around 3,000 rpm until the cooling fan(s) comes on.

1. Test-drive doing the following conditions:
 - CVT: Transmission D position/mode.
 - M/T: Transmission 2nd.
 - CVT: Decelerate from an engine speed of 3,200 rpm to 1,500 rpm with the throttle fully closed.
 - M/T: Decelerate from an engine speed of 2,800 rpm to 1,200 rpm with the throttle fully closed.
2. Repeat the test-drive several times.
3. Turn the vehicle to the OFF (LOCK) mode.
4. Turn the vehicle to the ON mode and wait 30 seconds.
5. Turn the vehicle to the OFF (LOCK) mode and wait an hour. The CKP pattern learn procedure is complete.

14. Install the Shift Lock Release

Remove the shift lock release cover from the glovebox and install the shift lock release cover as shown.



15. Activate the Audio System and Set the AM/FM Unit Presets

After installing the No. 18 BACK UP (10 A) and No. 19 AUDIO (15 A) fuses, set the ignition to ON, then press and hold the VOL/Power AUDIO knob for at least **2 seconds**. This synchronizes the audio unit with the vehicle and initializes the system for use.

NOTE: You may see the factory **InLine Diag** screen below, which means the audio unit is in the factory diagnostic mode. If you do, follow these steps to exit the mode; otherwise, skip them.



- Select **Start Diag**
- Press and release all the buttons on the steering wheel that are shown on the **InLine Diag** screen. The icons should turn green
- Press and release the Talk button. Make a loud sound (like snapping your fingers or clapping your hands) or say "testing" in a normal voice towards the microphone in the ceiling console. The mic level indicator should reach at least six bars
- When you have completed all the tests, the icons will be green. If any of them are red, troubleshoot the applicable system. Refer to the service information. select **Exit Diag** to exit the mode
- Set the ignition to OFF, then to ON, to make sure the **InLine Diag** screen does not reappear

Start the engine and if needed, press the VOL/Power AUDIO knob to turn the Audio unit on.

When the Enter Code screen appears, press and hold the knob for about **2 seconds**. This lets the PCM check that the vehicle's VIN matches the one saved in the unit. You will hear a long beep when the unit exits the anti-theft mode. Release the knob.

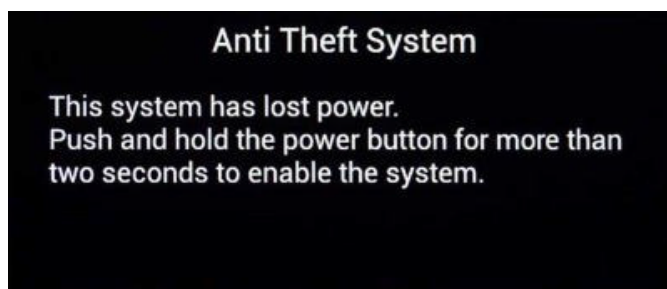

NOTE:

- If the audio unit does not exit the anti-theft mode, enter the anti-theft code using the audio touchscreen display



- If you need the anti-theft code, you can get it from the iN using the audio unit serial number. You can easily get that number without removing the audio unit. To get the serial number and the code, do this:
 - Press and hold the VOL/Power AUDIO knob, along with the HOME and SOURCE buttons at the same time. Hold until you hear a beep.
 - At the **Select Diagnosis Items** screen, select **Detail Information & Settings, Unit Check**, then **ECU Info**. The system runs a short diagnostic, then the audio unit serial number appears at the bottom of the screen.
 - Go to **Anti-theft Code Inquiry** on the iN and look up the five-digit anti-theft code.
 - If the code does not work, call the American Honda Warranty Department at **310-783-3240**. Do **not** call Tech Line.



16. Set the Clock

7" Color Touchscreen Audio (Standard & A-Spec)

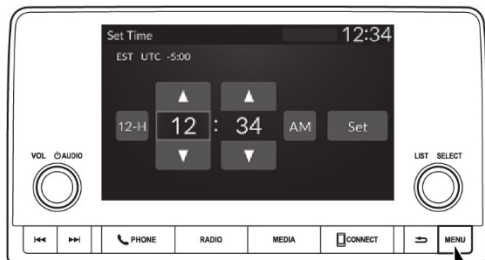
1. Set the ignition to ON.
2. Press the **MENU** button.



MENU BUTTON

3. Select **CLOCK SETTINGS**.
4. Select **AUTOMATIC TIME**, then select **OFF**.
5. Select **SET TIME**.
 - Select 12/24H to change the 12- or 24- hour clock.
 - Select  or .
 - Select **SET** to set the time.

9" Color Touchscreen Audio (A-Spec w/Tech & A-Spec w/Tech 6MT)



1. Set the ignition to ON.
2. Press the **HOME** button.

TO ADJUST DATE



TO ADJUST TIME



3. Select **GENERAL SETTINGS**
4. Select **SYSTEM**
5. Select **DATE & TIME**
6. Select **SET DATE & TIME**
7. Select **AUTOMATIC DATE & TIME** then select **OFF**.
8. Select **SET DATE** or **SET TIME**.
9. Select  or .

17. Voice Control System

The audio system features a voice control system that lets you use the audio and Bluetooth® HandsFreeLink® controls with just your voice. To interact with the system, use the Talk button on the steering wheel and the microphone in the ceiling console. This is the primary way to give commands to the system.



TALK BUTTON

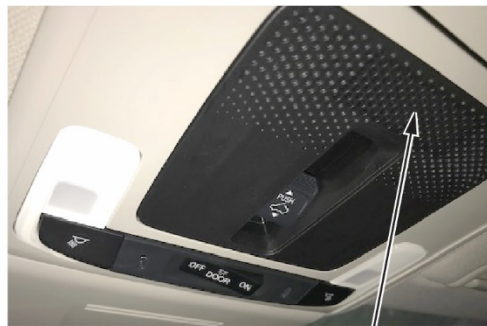

MICROPHONE

Talk button – To give a voice command, press and release this button, wait for the beep, and give the command.

Microphone – The microphone in the ceiling console picks up your voice commands.

NOTE:

- When the voice tutorial is turned on, you need to press and release the Talk button twice to give a command
- If the system does not understand your commands, select **System Setup** in the online owner's manual. Select **Voice Control System**, then select **Voice Recognition**

18. Rearview Camera

With the ignition set to ON, shift to Reverse. Make sure the rearview image with the distance guidelines appears on the display screen. Change the camera views by pressing the **CAMERA** button.

NOTE:

- When in Reverse, the other buttons are locked out
- If the image is foggy or dirty, clean the camera lens

19. Check/Refresh the SiriusXM Radio Dealer Demo Service (Except Alaska and Hawaii, if equipped)

The audio system comes from the factory and is activated with the SiriusXM® Radio dealer demo service. Once you install the No. 19 BACK UP (15 A), No. 37 BACK UP (30 A), No. 36 AUDIO (30 A), and No. 20 (15 A) (9" Touchscreen only) fuses, the system receives the full range of available channels. You can see a full list of available channels at www.siriusxm.com.

While watching the display, tune to several channels within the full channel lineup. The dealer demo service is activated when you can tune in to all channels.

NOTE:

- SiriusXM Radio is free to customers for the first **90 Days**. To keep getting coverage after that, they must subscribe by calling **800-852-9696** or going to www.siriusxm.com. They will need their eight-character radio ID (shown when tuned to channel 000) and major credit card.
- SiriusXM Radio is not available in Alaska or Hawaii.

Clear any information that was saved during the PDI.

- Set the ignition to ACCESSORY
- Turn on the audio unit
- From the Home screen, select **Settings, System**, then **Factory Data Reset**. A confirmation screen appears
- Select **Continue**. A second confirmation screen appears
- Select **Continue**. The system resets

20. Placing Windshield Wipers into Maintenance Mode

Should the need arise to replace the vehicle's windshield wipers, it is best to place the wipers into maintenance mode to prevent any damage to the wiper arms or surrounding bodywork.

To place them into this mode, do the following steps:

1. Set the ignition to ON, then to VEHICLE OFF.
2. Within **10 seconds** of setting the power mode to VEHICLE OFF, hold the wiper switch in the MIST position for more than **2 seconds**.
3. Both wiper arms are set to the maintenance position.
4. Lift both wiper arms away from the windshield.
5. Return both wipers to the windshield before canceling maintenance mode. Remove the wipers from maintenance mode by placing the power to ON and briefly moving the wiper switch to MIST.
6. **Failure to place the wipers in maintenance mode may cause damage to the wiper motor and/or linkage and increase the likelihood of paint damage.**

21. Event Data Recorders

This vehicle is equipped with an Event Data Recorder (EDR)

The main purpose of an EDR is to record, in certain crash or near crash-like situations, such as an airbag deployment or hitting a road obstacle, data that will assist in understanding how a vehicle's systems performed. The EDR is designed to record data related to vehicle dynamics and safety systems for a short period, typically **30 seconds** or less. The EDR in this vehicle is designed to record such data as:

- How various systems in your vehicle were operating
- Whether or not the driver and passenger safety belts were buckled/fastened
- How far (if at all) the driver was depressing the accelerator and/or brake pedal
- How fast the vehicle was traveling

Special equipment is required to read data recorded by an EDR, and access to the vehicle or the EDR is needed. In addition to the vehicle manufacturer, other parties, such as law enforcement, that have the special equipment, can read the information if they have access to the vehicle or the EDR.

The data belongs to the vehicle owner and may not be accessed by anyone else except as legally required or with the permission of the vehicle owner.

END